

suprabeam®
DENMARK

Q3 classic

Light control function

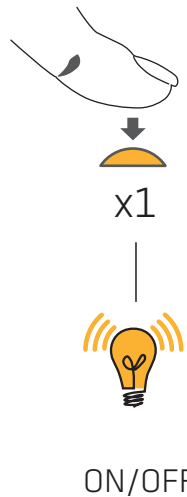

Changing Battery

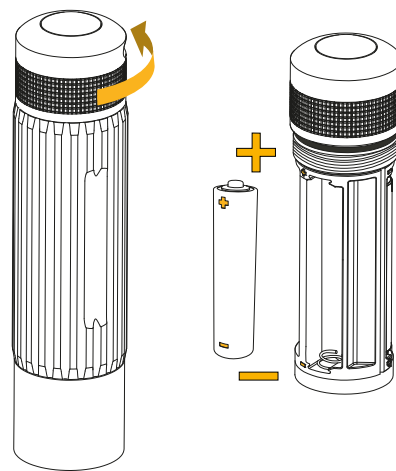

Specifications

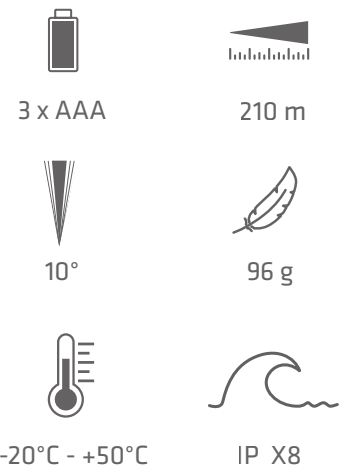

Additional online information



Warning



Waterproof

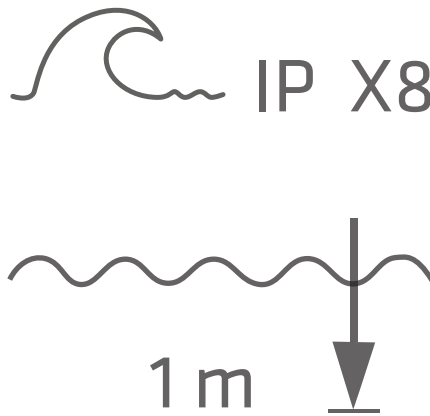

Accessories for Q3classic

Q3 colourfilters



Q3 bikeholder



This manual may contain typographical errors. Data and information are subject to change without notice

Steiner A/S
Dyssen 3
DK-8200 Aarhus N
Phone: +45 87 52 52 12
Fax: +45 87 52 52 15
info@suprabeam.com
www.suprabeam.com

For the technician in demanding work situations, it is essential with the best gear available. The Q1 provides remarkable power and comes in a convenient size for your pocket.

A PURE SUPRABEAM CLASSIC...

POWERFUL PEN TORCH
ROTATING HYPERFOCUS
SMALL AND RELIABLE



Q1

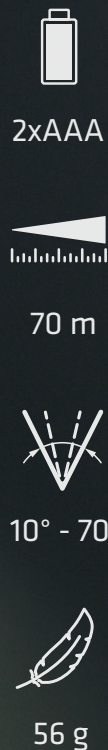

suprabeam®

